

1 Vertical Ladder

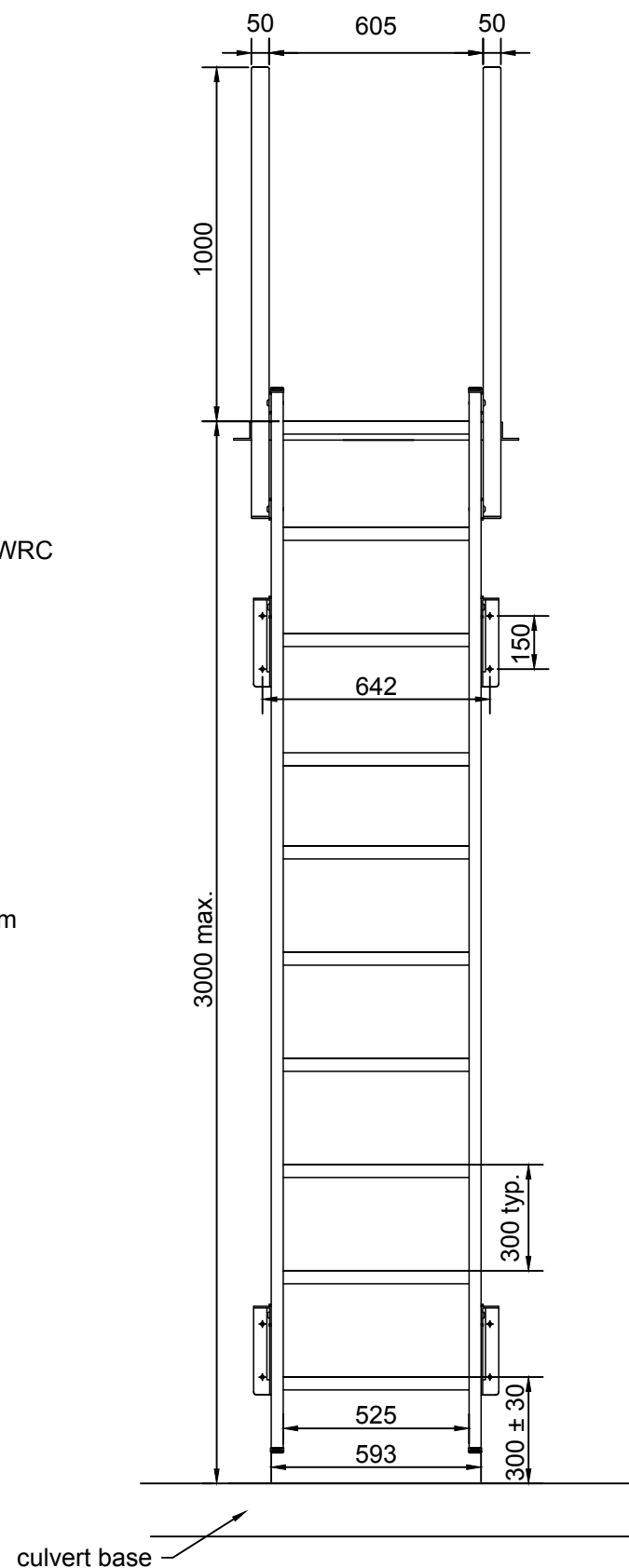

2 Ladder Front view

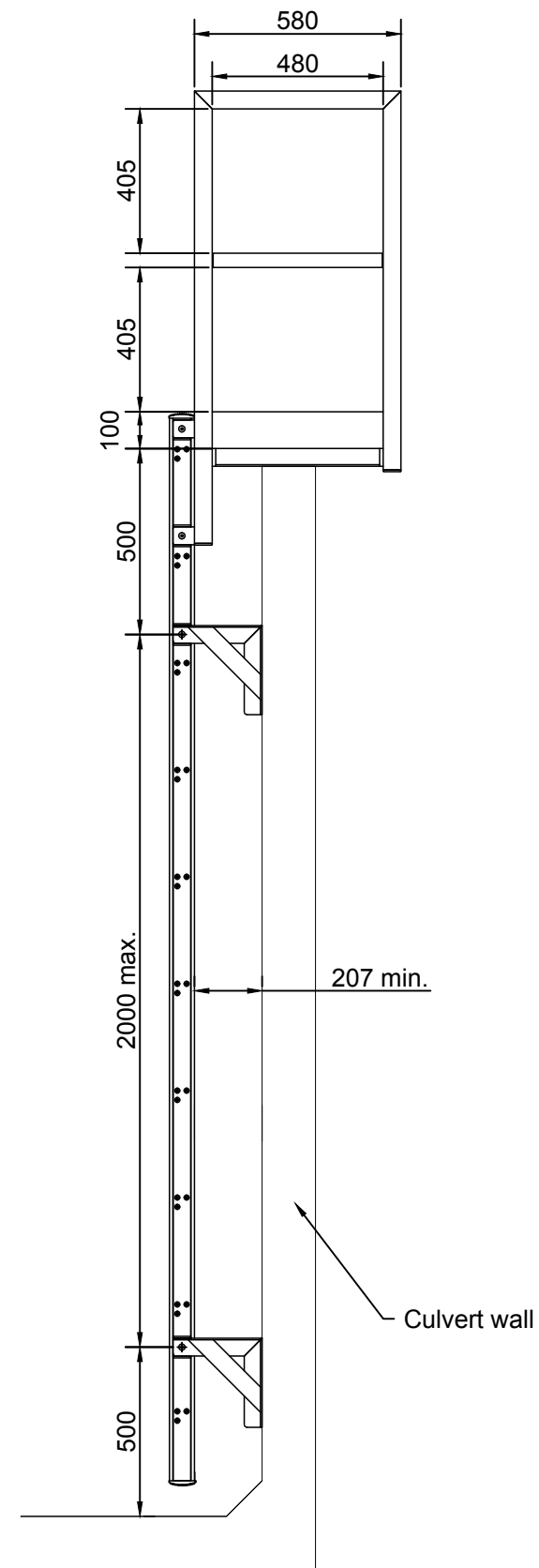

3 Ladder Side View

NOTES

1. Read notes on all sheets together with specifications and notify engineer immediately of any discrepancies.
2. All dimensions in millimeters unless otherwise specified.
3. All bolts/threaded rods hot dip galvanised.
4. Estimated unit weight = 30kg (3.0m ladder)
5. This unit has been designed where applicabl to meet the requirements of AS1657:2018 - Fixed Platforms, Walkways , Stairways and Ladders- Design, Construction and Installation.
6. Ladder platform and bracket supplied by Waikato Regional Council.

0	Construction Issue	A Morphet	29/11/19
Rev	Description	Approved	Date



Standard Drawings

Vertical Ladder

Date.	29 November 2019	Drawn.	A McCaughan
		Checked.	M Farrell

Drawing Number	WRC - 1692	REV	0
----------------	------------	-----	---

Scale.	As indicated	@ A3
--------	--------------	------