

**PLAN**

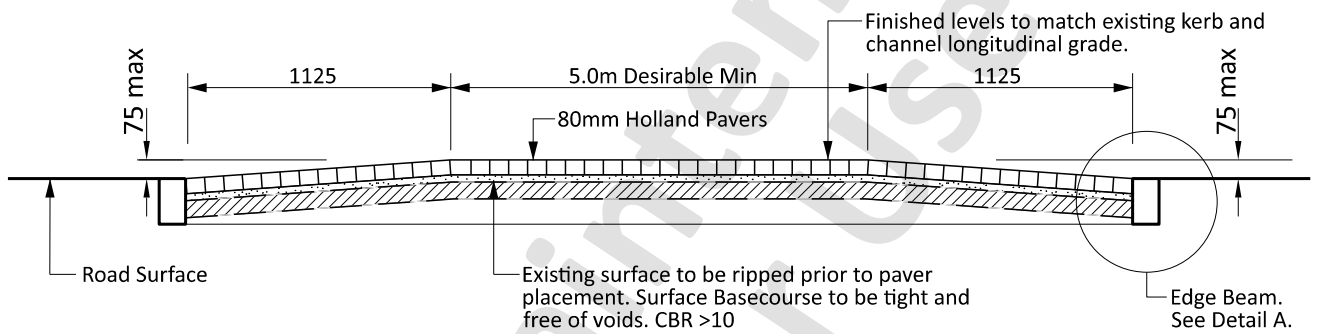

**SECTION A - A (RAISED PEDESTRIAN RAMP)**

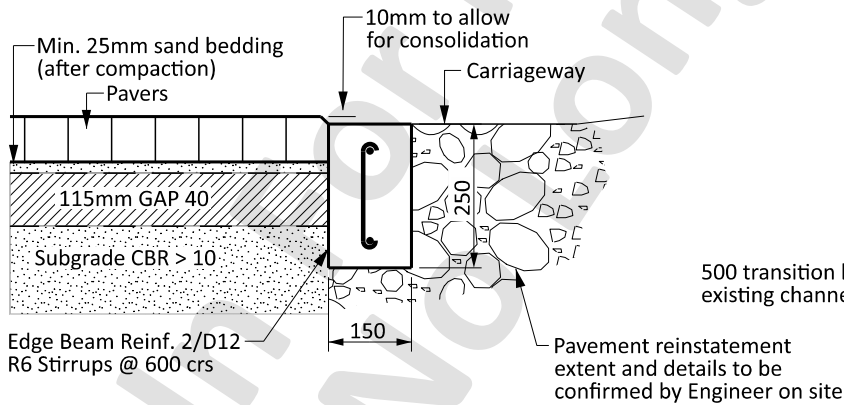

**DETAIL A**

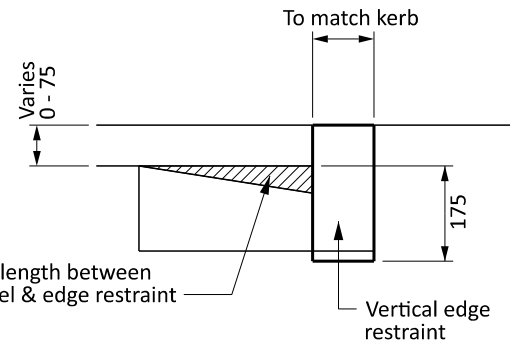

**DETAIL B**

**NOTES:**

1. Pavers to be Autumn Tones
2. Where existing subgrade is unsatisfactory excavate and replace with imported pitsand
3. Sand bedding to be No 1 grade processed sand