

**PLAN**

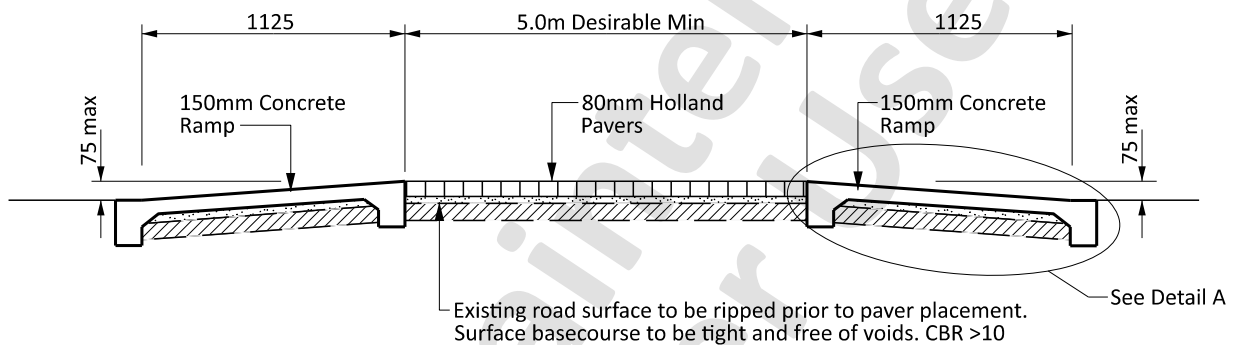

**SECTION A - A**

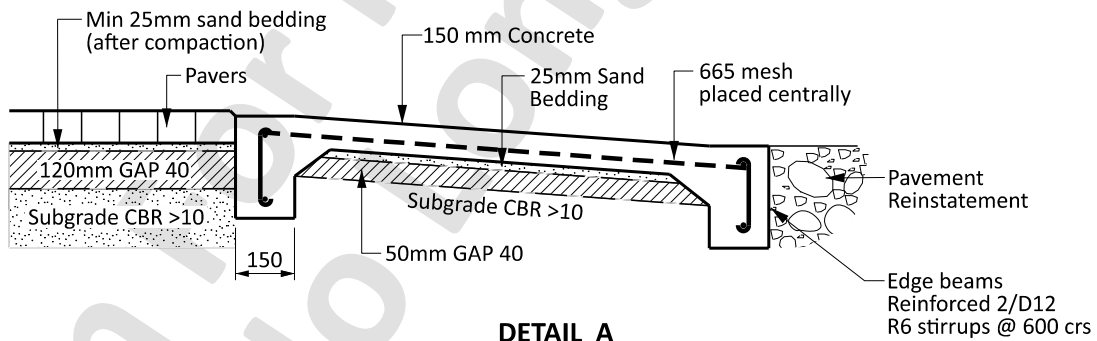

**DETAIL A**

**NOTES:**

1. Pavers to be Autumn Tones
2. Where existing subgrade is unsatisfactory excavate and replace with imported pitsand
3. Sand bedding to be No 1 grade processed sand
4. Concrete ramps to have a light broomed finish, and may be coloured on approval of the Engineer

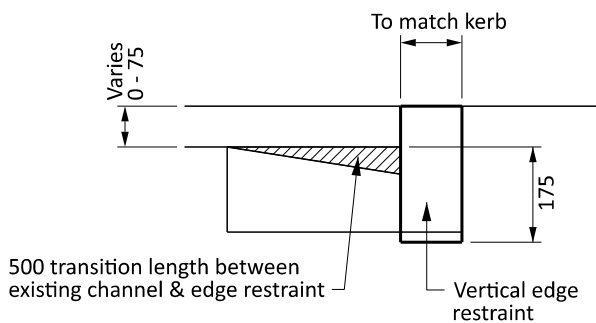

**DETAIL B**