

**EXISTING KERB IN SOUND CONDITION**

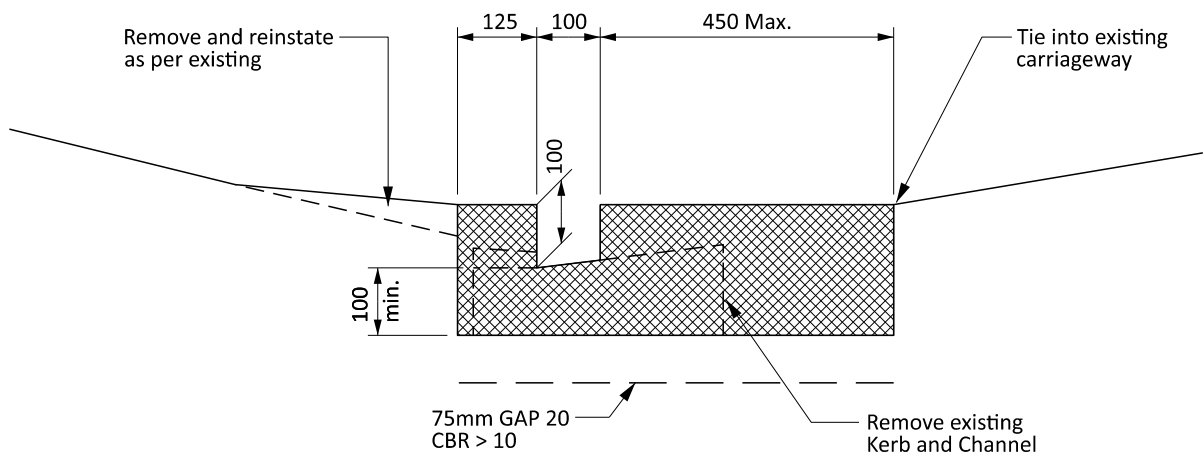

**RESIDENTIAL (EXISTING KERB IN POOR CONDITION)**

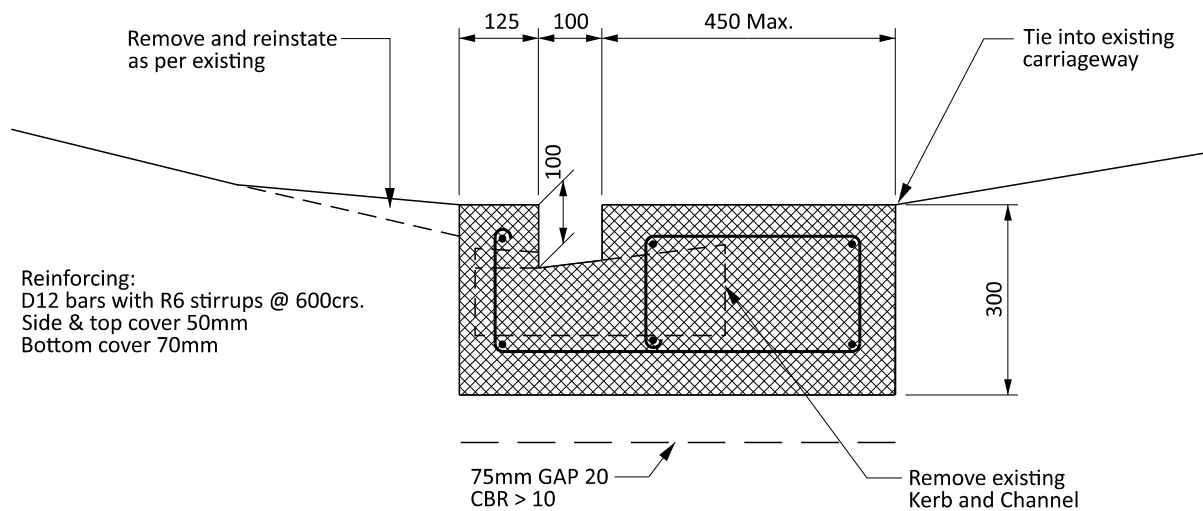

**INDUSTRIAL**