

### KERB ENTRY

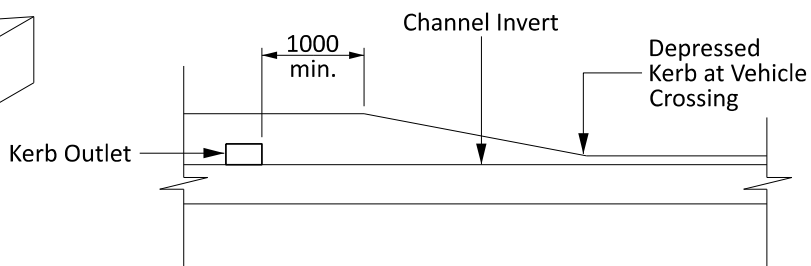

### VERTICAL KERB

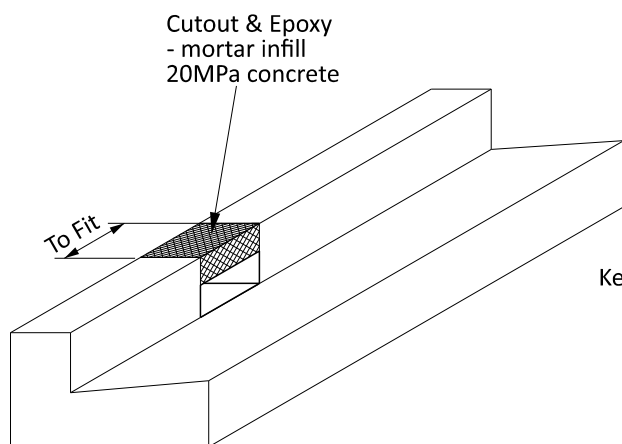
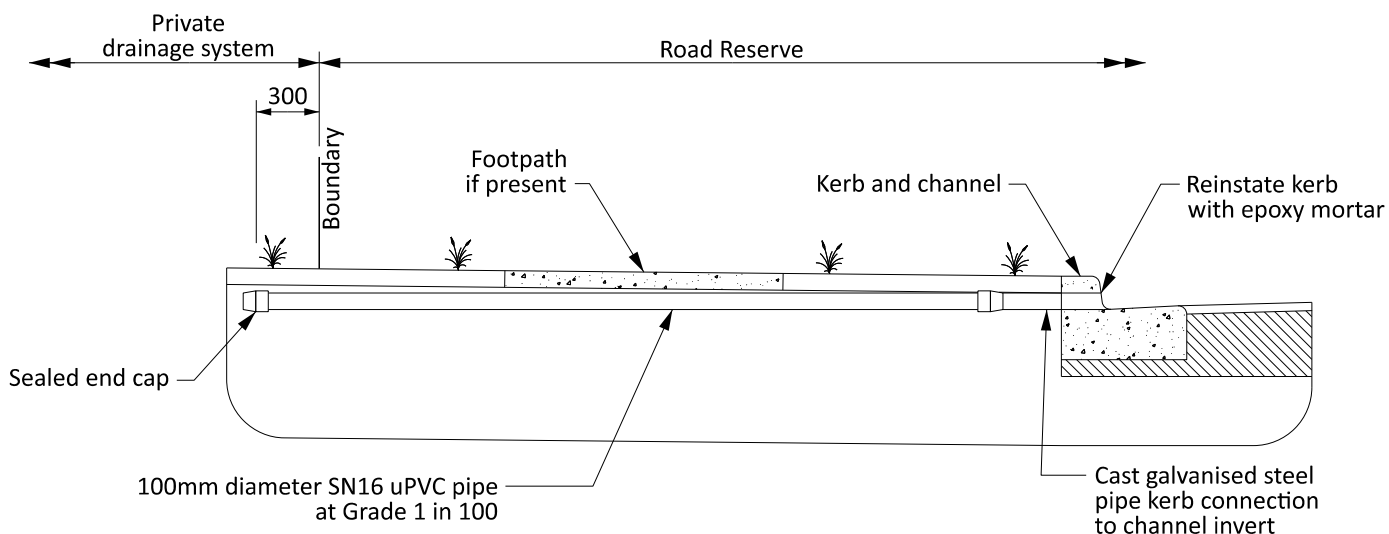

### LONGITUDINAL SECTION