

PLAN
SCALE 1:25

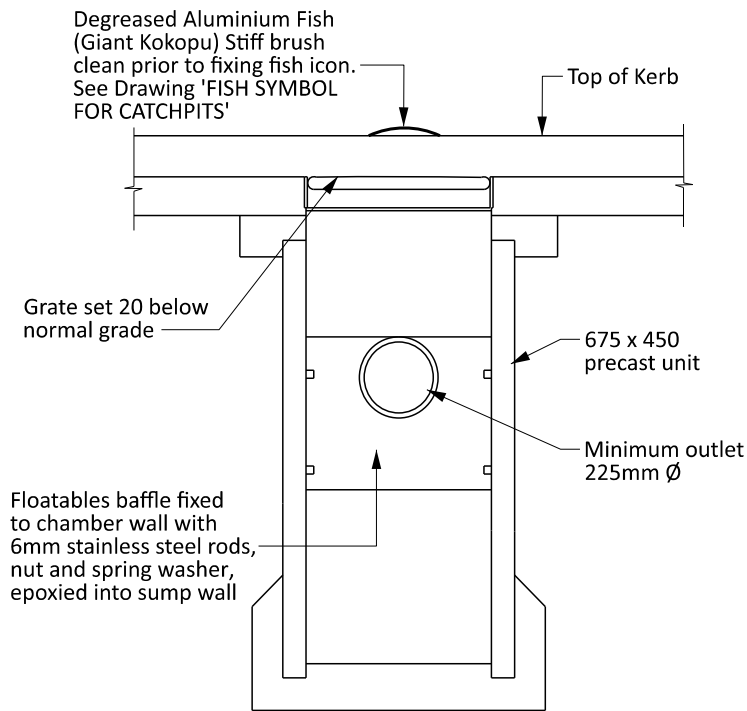

SECTION A-A
SCALE 1:25

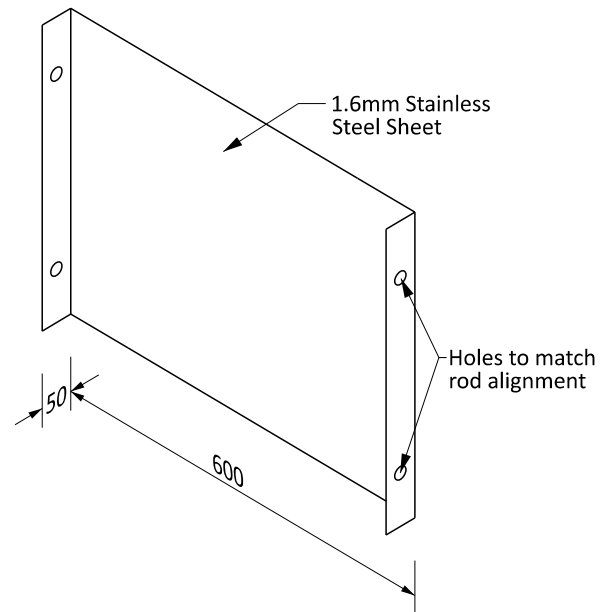

FLOATABLES BAFFLE DETAIL
Not to Scale

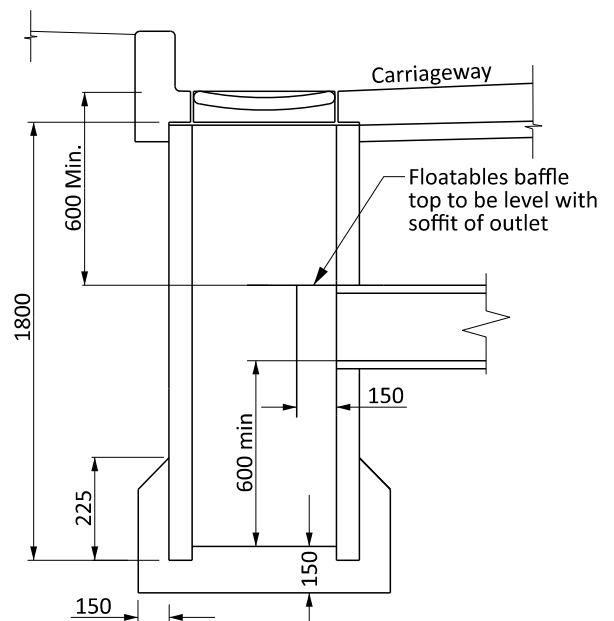

SECTION B-B
SCALE 1:25

NOTES:

1. Epoxy product to be "Ramset Epcon C6" 2 pot epoxy or approved equivalent.
2. All in-situ concrete shall have a minimum 28 day strength of 20MPa