

SECTION A

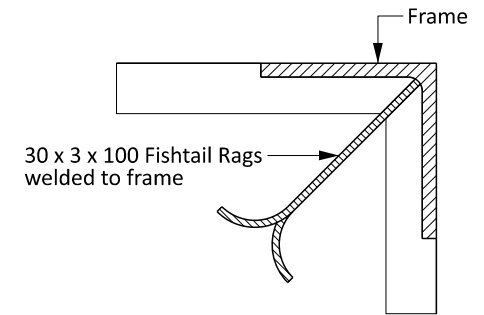

FISHTAIL RAG TYPICAL DETAIL

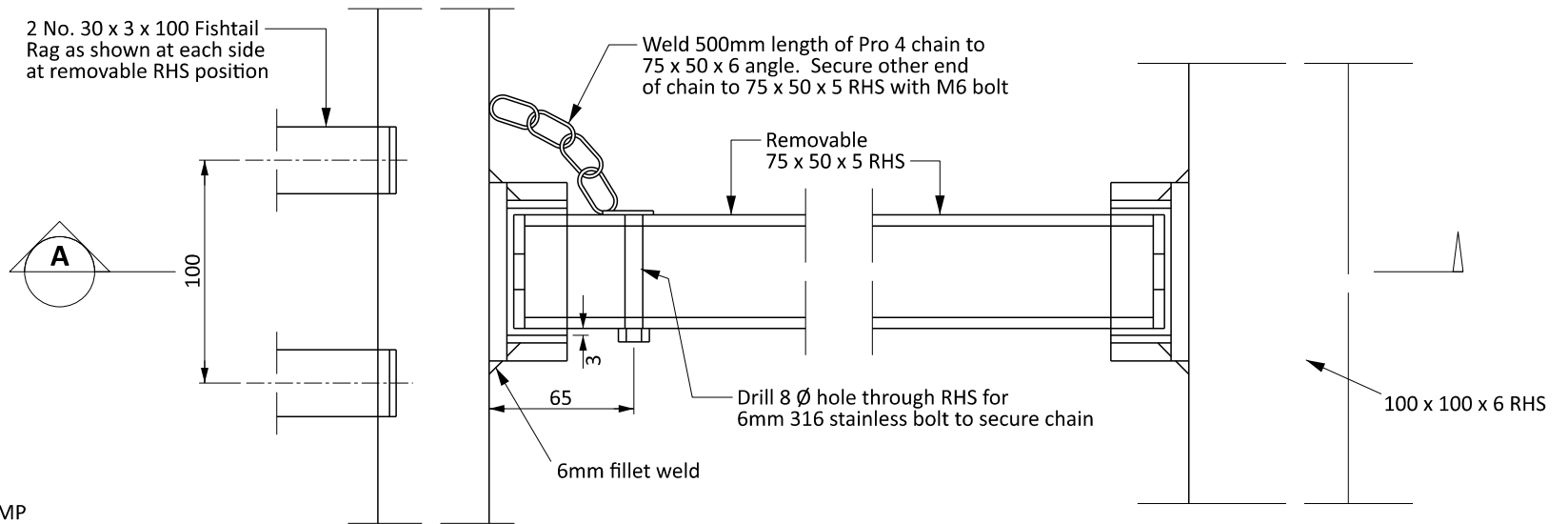

DETAIL 1

DETAIL 2

NOTES:

1. See Drawing 'WASTEWATER PUMP STATION LID FRAME' for plan.
2. All 316 stainless steel