

LEFT ELEVATION

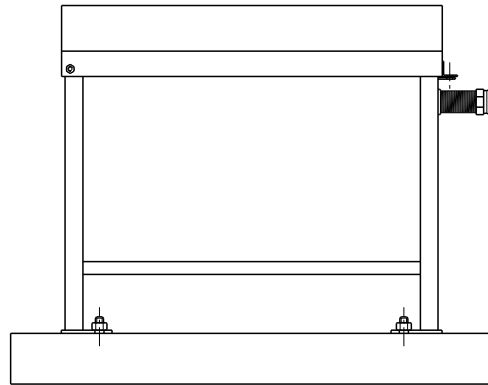

FRONT ELEVATION

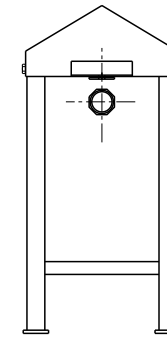

RIGHT ELEVATION

METAL CAGE

Refer Drawing 'WASTEWATER PUMP STATION WATER SUPPLY BACKFLOW PREVENTION CAGE' for details

