

TOP SLAB FOR DN750 SHALLOW CHAMBER

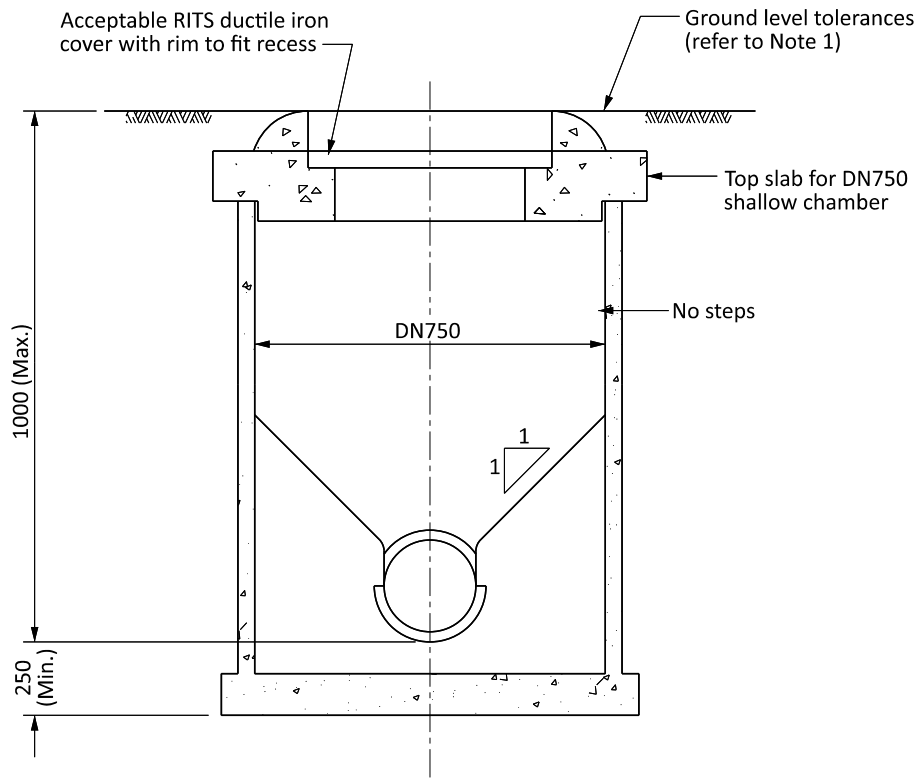

DN750 INTERNAL SHALLOW CHAMBER

To be used only on pipes of DN100 to DN300 and where depth of invert is less than 1000mm

NOTES:

1. Ground level tolerances: Pavement +0mm, -5mm
 Berm +5mm, -5mm
 Footpath +5mm, -0mm
2. Manhole lid & frame to follow ground slope.