

RESIDENTIAL RURAL - 1 TO 5 LOTS

Speed Environment 30kph max

1 TO 9 LOTS - DIMENSION TABLE					
Nº of Lots	A	B	C	D	Maximum Length
1	6.0m	1.0m	3.0m	1.0m	
2 - 5*	9.0m	1.0m	3.0m	1.0m	Passing Bay every 75m
6 - 9*	12.0m	1.5m	6.0m	2 x 1.75m	Passing Bay every 75m

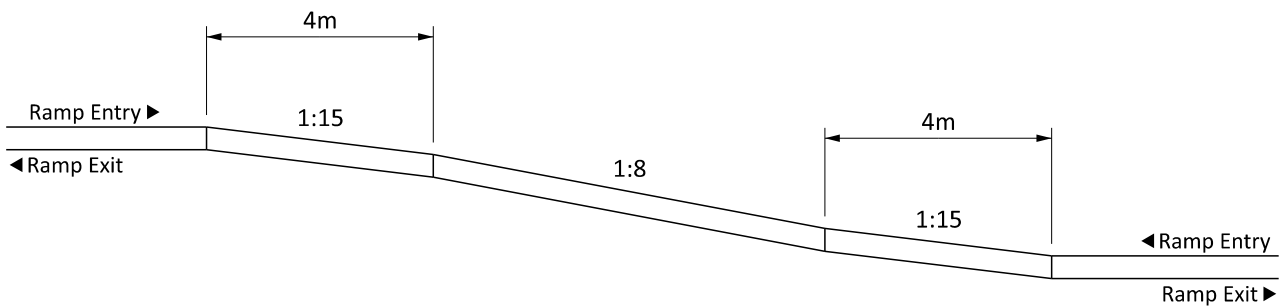

RURAL ACCESS GRADIENTS

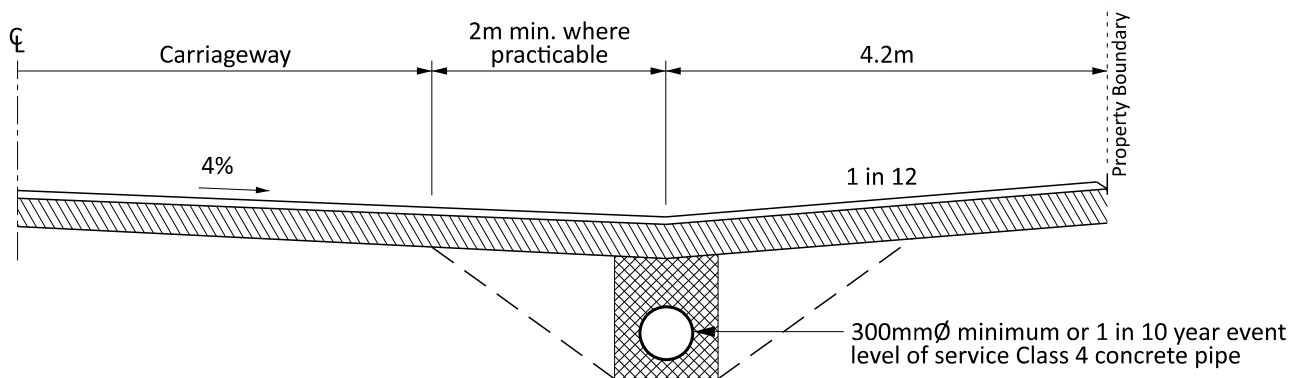

RURAL ACCESS

NOTES:

1. Agriculture and Farming Lots will required a Specific Design.
2. No more than 9 Lots can be yielded from a Access Way. An 18-20m road corridor is required where more future sud-division is anticipated.